



## ETR-55T Mobile Trolley Lift



### **Features**

- Support 55" LCD Mon/ Display
- Support RF wireless remote control, Up, Down, stop control switch for remote control
- Supply RS232/ RS485 Control
- motor , Brake Function

### **Specification**

- Material: Steel
- Color: Phenolic plastics , Surface treatment: Bake of high temperature
- Wall Mount bracket for 55" LCD Mon/ Display
- Load weight: 60kg

-Power Supply: 220 V / 50 ~ 60 Hz

-Choose to rotate 180 degrees (left and right) ,

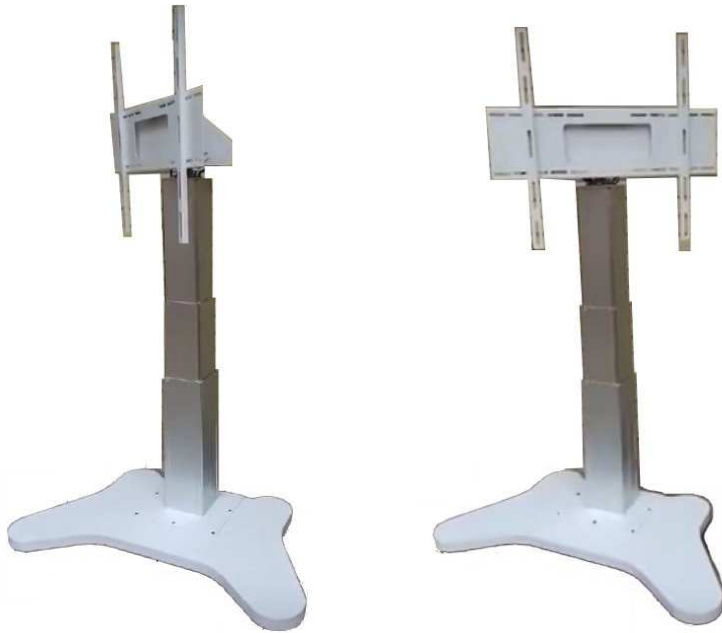

or flip 90 degrees (up and down)

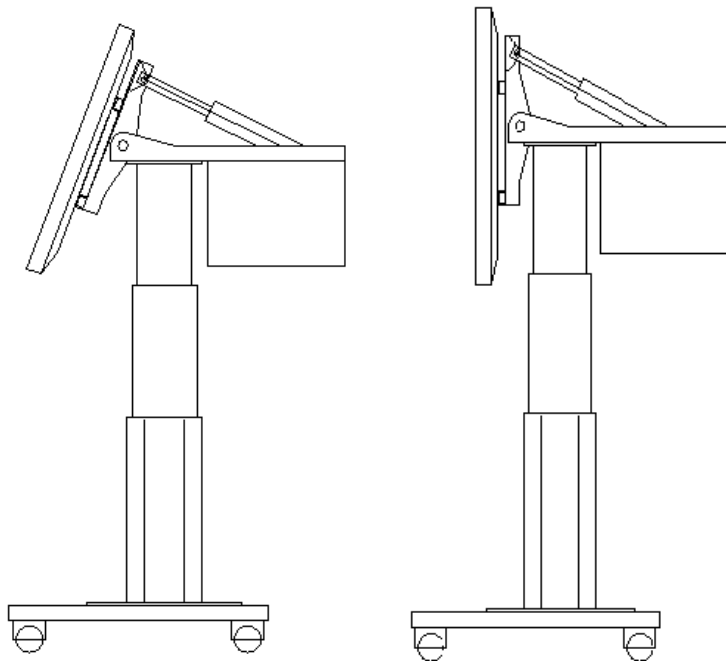

## Dimension

Electric height adjustment : 500mm

-Electric Tilt adjustment: 90 degree